

Specification Manual

IGS Sensing Gear Wheel

Description

For used with IGS Series encoder, to measure the rotating speed and position of the mechanical in a contactless manner.



■ Specification

Type Code	
	M X XXX – XXX ① ② ③
①	Module Choice 3 : 0.3 module 4 : 0.4 module 5 : 0.5 module
②	Gear Teeth Choice EX: 128 : 128 Teeth 256 : 256 Teeth 512 : 512 Teeth
③	Inner Diameter (mm) Ex: 180 : 180 mm

Standard Selection Table

Specification	OD (A)	ID (B)	PCD (C)	Mounting Hole Diameter (D)	Number of teeth
Module 0.4					
M4 512-180	205.6	180	194.4	4.5	512
M4 384-108	154.4	108	120	4.5	384
M4 384-125	154.4	125	140	4.5	384
M4 256-82	103.2	82	92	4.5	256
M4 192-60	77.6	60	68	3.5	192
M4 192-50	77.6	50	64	3.5	192
M4 128-35	52	35	43	3.5	128
M4 128-30	52	30	41	3.5	128
M4 64-10	26.4	10	-	-	64
Module 0.5					
M5 256-95	129	95	112	4.5	256
M5 128-50	65	50	57	3.5	128
M5 128-40	65	40	53	4.2	128
M5 64-20	33	20	25.2	3.5	64

Length unit: mm

Customized gear is available, please contact us for more information.

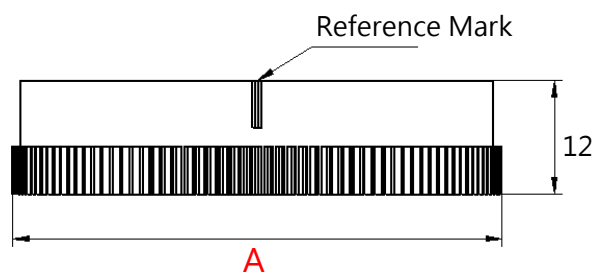
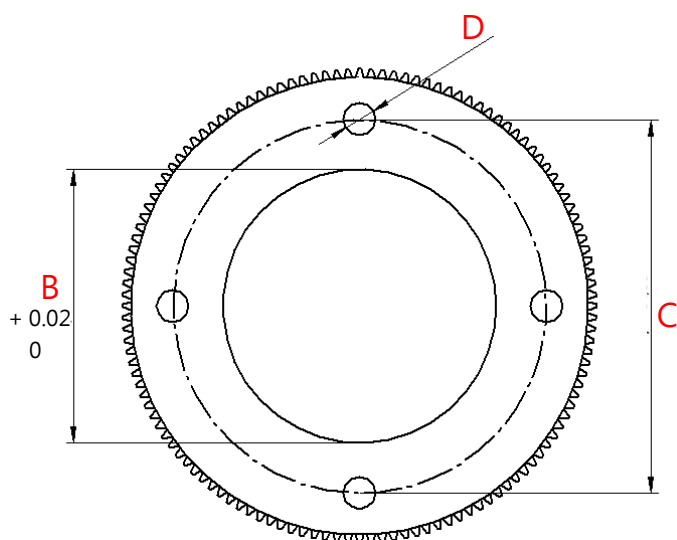

Length unit: mm